

	Montageanleitung	Werkstatteinrichtungs-Set
DE	Montageanleitung	Werkstatteinrichtungs-Set
EN	Translation of the assembly instructions	Workshop equipment set
FR	Traduction des instructions de montage	Kit d'équipement d'atelier
IT	Traduzione delle istruzioni di montaggio	Set di attrezzature per officina
ES	Traducción de las instrucciones de montaje	Equipo de taller
NL	Vertaling van de montagehandleiding	Set Werkplaatsinrichting
CZ	Překlad montážního návodu	Sada dílenského vybavení
SK	Preklad návodu na montáž	Sada dielenského vybavenia
PL	Tłumaczenie instrukcji montażu	Zestaw urządzeń warsztatowych
HU	Az összeszerelési útmutató fordítása	Műhely felszerelés készlet



WERKSTATTEINRICHTUNGS-SET GWS 6-TLG
#40495



DEUTSCH

ACHTUNG! Möbelstücke können herunterfallen, was zu ernsten oder sogar lebensgefährlichen Verletzungen führen kann. Um dies zu verhindern, achten Sie auf eine korrekte und ausreichende Befestigung an der Wand. Nutzen Sie hierfür die beige packten Vorrichtungen.

Prüfen Sie das Wandmaterial und verwenden Sie ausschließlich Schrauben und Dübel, die für die zu erwartende Belastung geeignet sind.

Befolgen Sie jeden Schritt dieser Anleitung sorgfältig. Bei Unklarheiten wenden Sie sich bitte an den Fachhandel oder unseren Kundenservice.

ENGLISH

WARNING! Pieces of furniture can fall down, causing serious or even life-threatening injuries. To prevent this, make sure that the furniture is correctly and adequately fixed to the wall. Use the enclosed fixtures for this purpose.

Check the wall material and use screws and dowels that are suitable for the expected load.

Follow each step of these instructions carefully. If anything is unclear, please contact the specialist trade or our customer service.

FRANÇAIS

ATTENTION! Les meubles peuvent tomber, ce qui peut entraîner des blessures graves, voire mortelles. Pour éviter cela, veillez à ce que le meuble soit correctement et suffisamment fixé au mur. Utilisez à cet effet les dispositifs fournis.

Vérifiez le matériau du mur et utilisez des vis et des chevilles adaptées à la charge prévue.

Suivez attentivement chaque étape de ces instructions. En cas d'incertitude, veuillez vous adresser au commerce spécialisé ou à notre service clientèle.

ITALIANO

ATTENZIONE! I mobili possono cadere, causando lesioni gravi o addirittura mortali. Per evitare che ciò accada, assicurarsi che i mobili siano fissati correttamente e adeguatamente alla parete. A tale scopo, utilizzare i dispositivi in dotazione.

Controllare il materiale della parete e utilizzare viti e tasselli adatti al carico previsto.

Seguire attentamente ogni fase di queste istruzioni. Se qualcosa non è chiaro, contattare il rivenditore specializzato o il nostro servizio clienti.

ESPAÑOL

¡ATENCIÓN! Los muebles pueden caerse y causar lesiones graves o incluso mortales. Para evitarlo, asegúrese de que los muebles están correcta y adecuadamente fijados a la pared. Utilice para ello las fijaciones adjuntas.

Compruebe el material de la pared y utilice tornillos y tacos adecuados para la carga prevista.

Siga cuidadosamente cada paso de estas instrucciones. Si algo no está claro, póngase en contacto con el comercio especializado o con nuestro servicio de atención al cliente.

NEDERLANDS

LET OP! Meubels kunnen omvallen en ernstige of zelfs levensbedreigende verwondingen veroorzaken. Om dit te voorkomen, moet je ervoor zorgen dat de meubels correct en voldoende aan de muur zijn bevestigd. Gebruik hiervoor de bijgeleverde bevestigingen.

Controleer het materiaal van de muur en gebruik schroeven en pluggen die geschikt zijn voor de verwachte belasting.

Volg elke stap van deze instructies zorgvuldig op. Als er iets onduidelijk is, neem dan contact op met de vakhandel of onze klantenservice.

ČEŠTINA

POZOR! Kusy nábytku mohou spadnout a způsobit vážná nebo dokonce život ohrožující zranění. Abyste tomu zabránili, ujistěte se, že je nábytek správně a vhodně připevněn ke stěně. K tomuto účelu použijte přiložené úchytky.

Zkontrolujte materiál stěny a použijte šrouby a hmoždinky, které jsou vhodné pro očekávané zatížení.

Pečlivě dodržujte jednotlivé kroky těchto pokynů. V případě nejasností se obraťte na odborný obchod nebo na náš zákaznický servis.

SLOVENSKÝ

POZOR! Kusy nábytku môžu spadnúť a spôsobiť vážne alebo dokonca život ohrožujúce zranenia. Aby ste tomu zabránili, uistite sa, že je nábytok správne a vhodne pripevnený k stene. Na tento účel použite priložené úchytky.

Skontrolujte materiál steny a použite skrutky a hmoždinky, ktoré sú vhodné pre očakávané zaťaženie.

Starostlivo dodržiavajte každý krok týchto pokynov. Ak je niečo nejasné, obráťte sa na odborný obchod alebo na náš zákaznický servis.

POLSKI

UWAGA! Meble mogą spaść, powodując poważne, a nawet zagrażające życiu obrażenia. Aby temu zapobiec, należy upewnić się, że meble są prawidłowo i odpowiednio przymocowane do ściany. W tym celu należy użyć dołączonych uchwytów.

Sprawdź materiał, z którego wykonana jest ściana i użyj wkrętów i kołków odpowiednich do przewidywanego obciążenia.

Należy dokładnie przestrzegać każdego kroku niniejszej instrukcji. W razie jakichkolwiek niejasności prosimy o kontakt ze specjalistami lub naszym działem obsługi klienta.

MAGYAR

FIGYELEM! A bútordarabok leeshetnek, súlyos vagy akár életveszélyes sérüléseket okozva. Ennek megelőzése érdekében győződjön meg arról, hogy a bútorkat helyesen és megfelelően rögzítették a falhoz. Használja erre a célra a mellékelt rögzítőelemeket.

Ellenőrizze a fal anyagát, és olyan csavarokat és dübeleket használjon, amelyek megfelelnek a várható terhelésnek.

Kövesse gondosan az utasítások minden egyes lépését. Ha valami nem világos, forduljon a szakkereskedéshez vagy ügyfélszolgálatunkhoz.

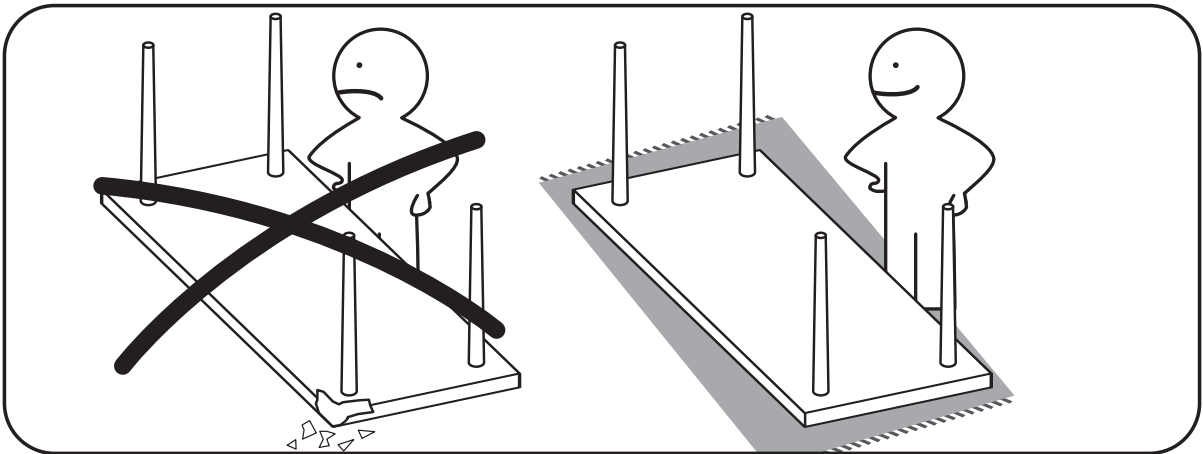
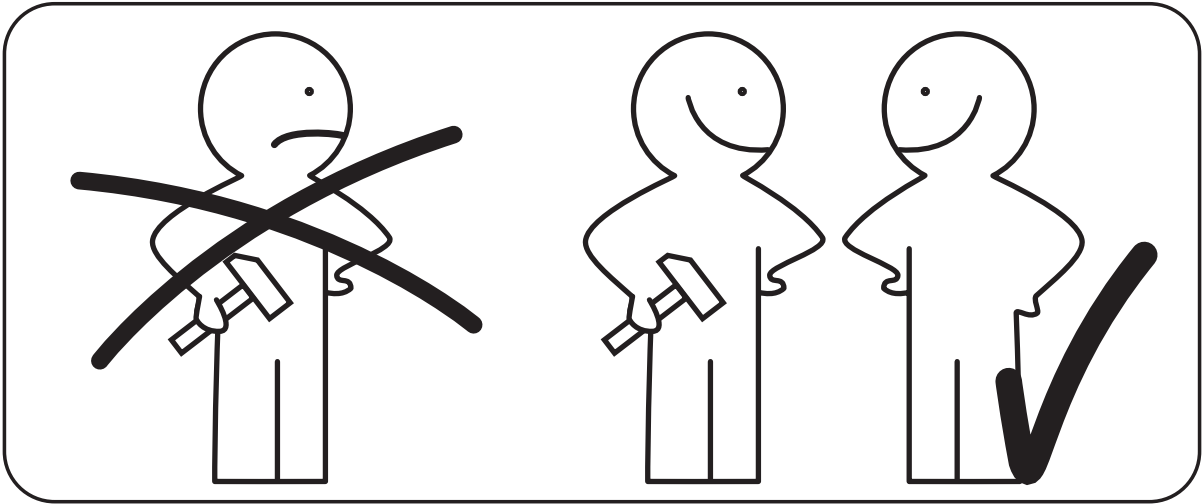
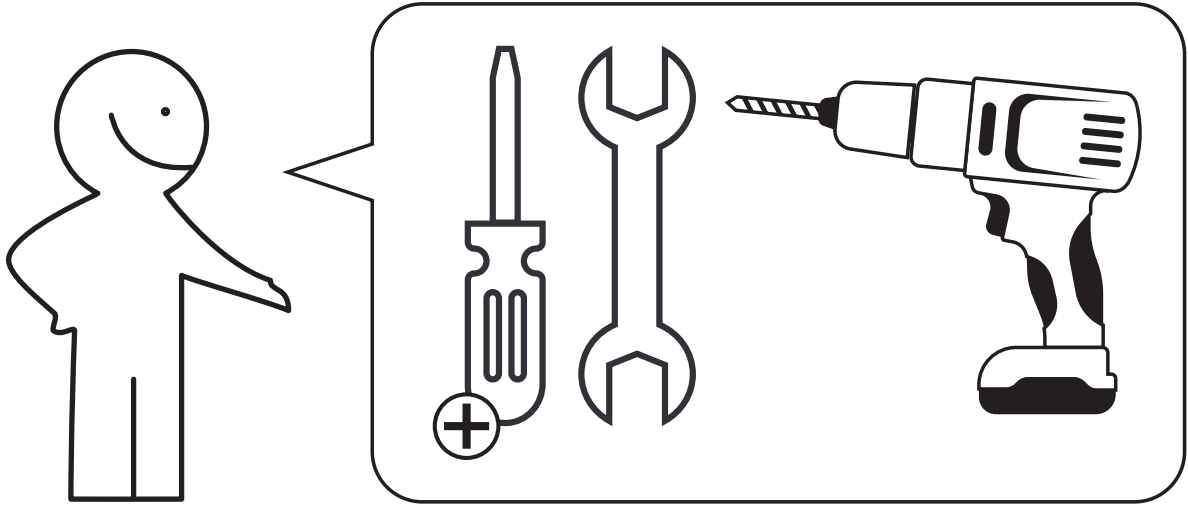

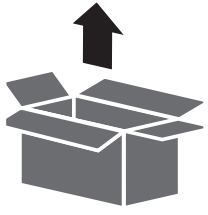

40495.1

1

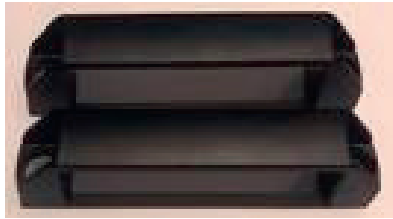

2

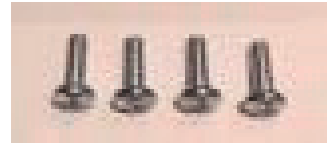

3



4



40495.2

5

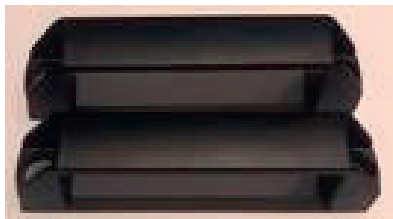

6

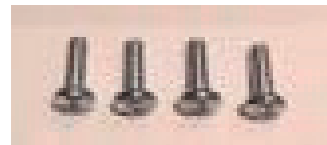

7



8



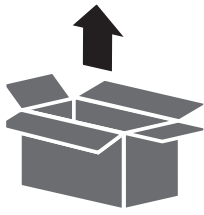

9

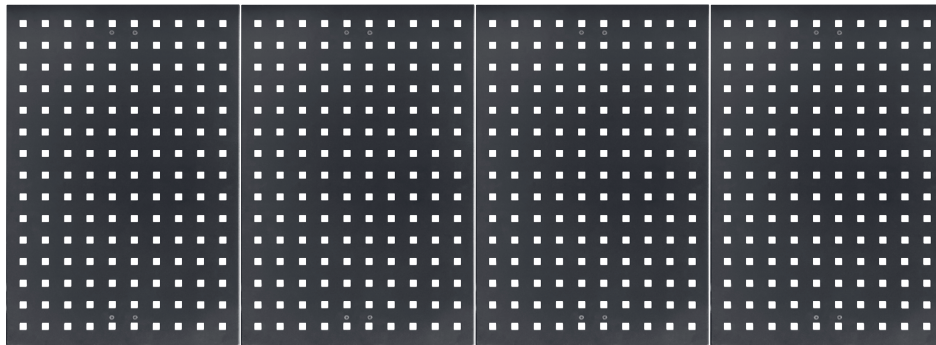

40495.3

10



11

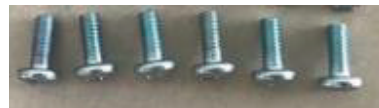

12



40495.4

15



16



13



14



17



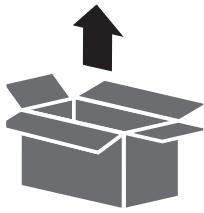

18 40495.5



19

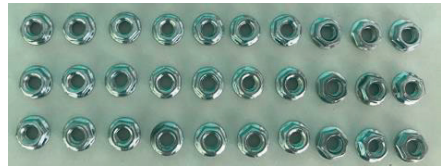

20



21 40495.6



22



23



24



25



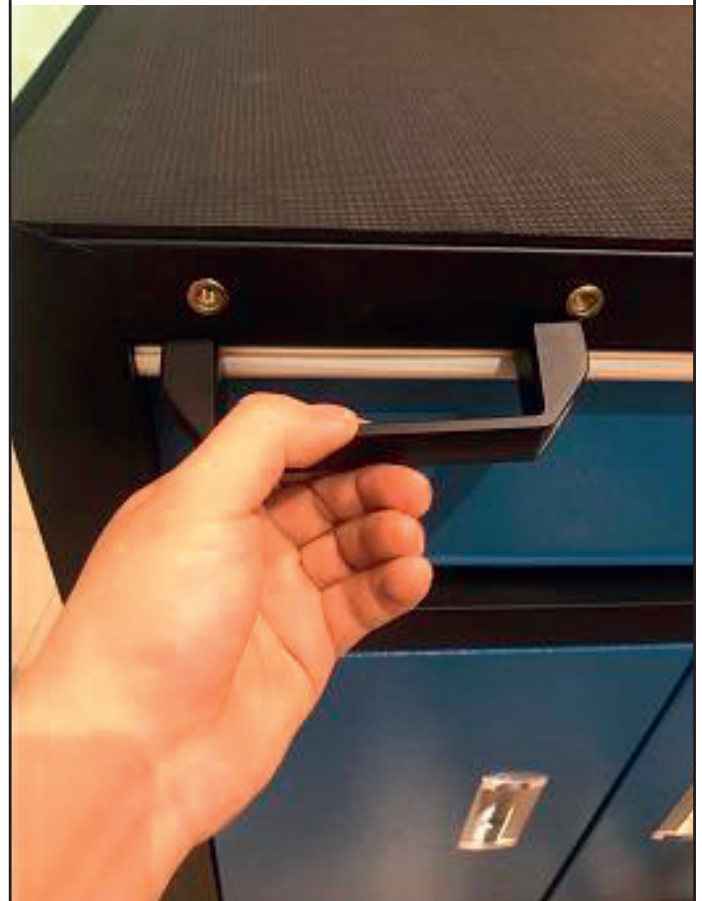
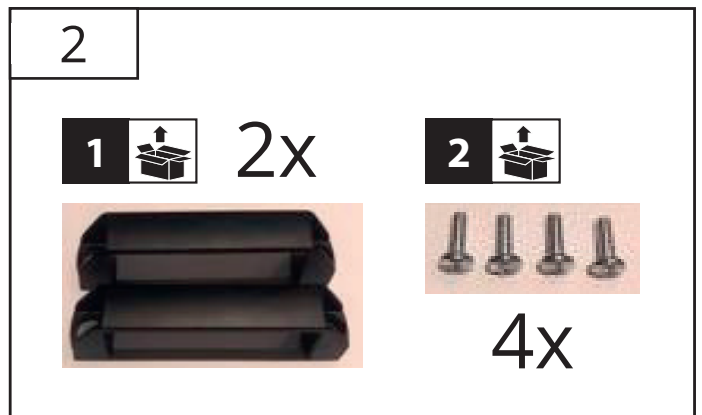
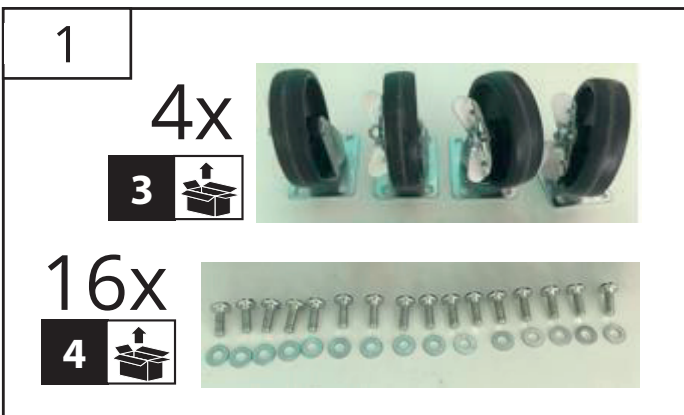
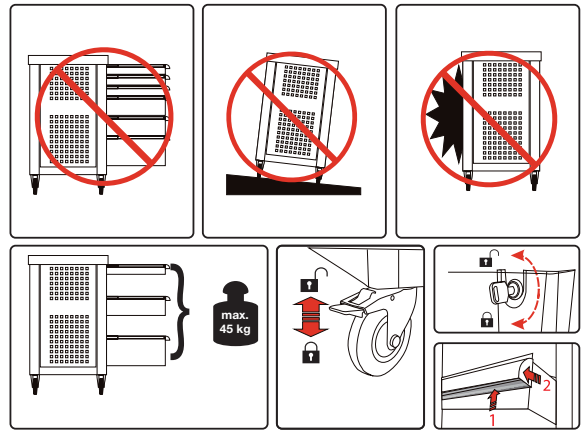

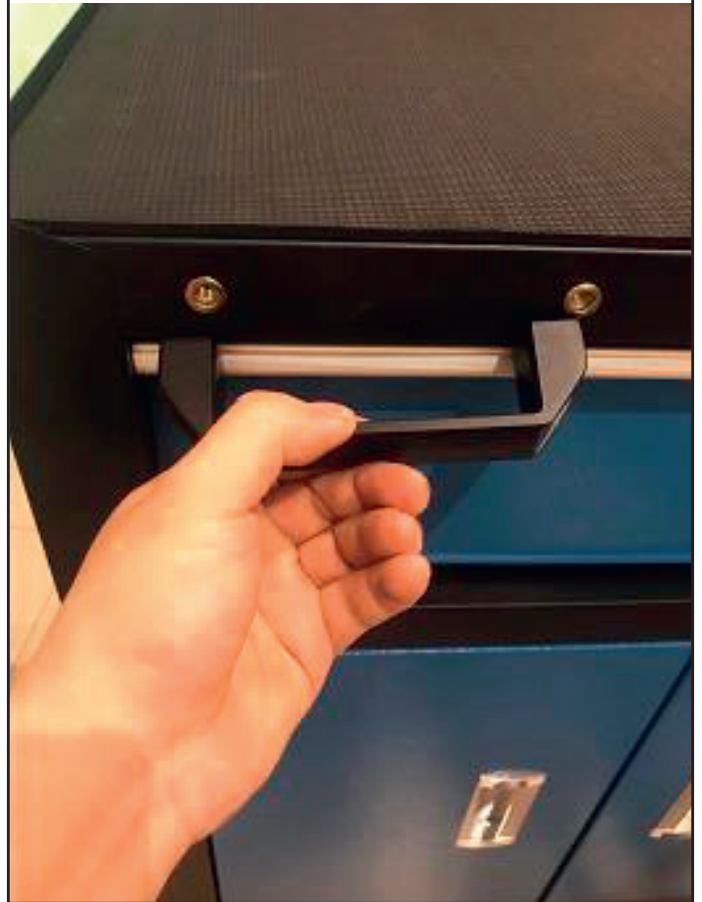
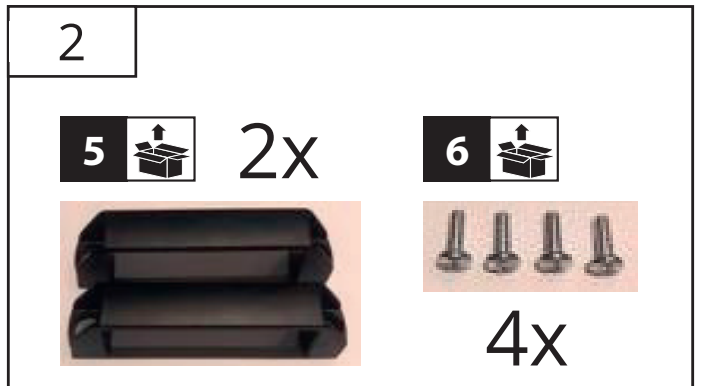
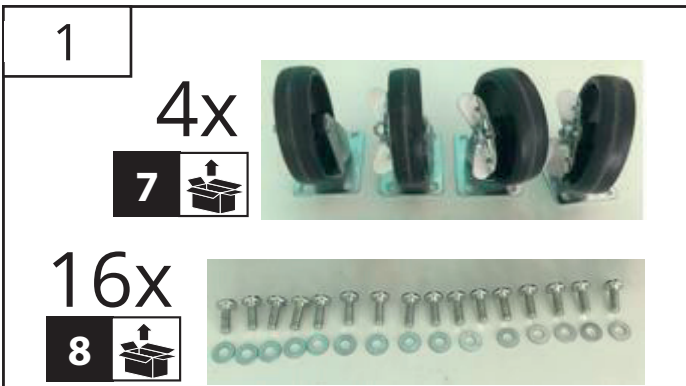
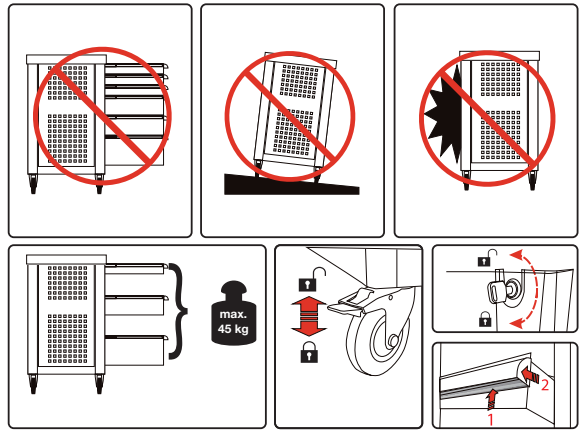

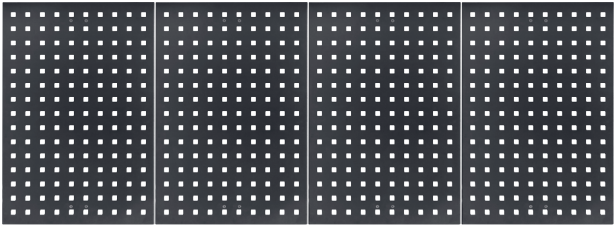

40495.3

1

6x

10 



6x

11 

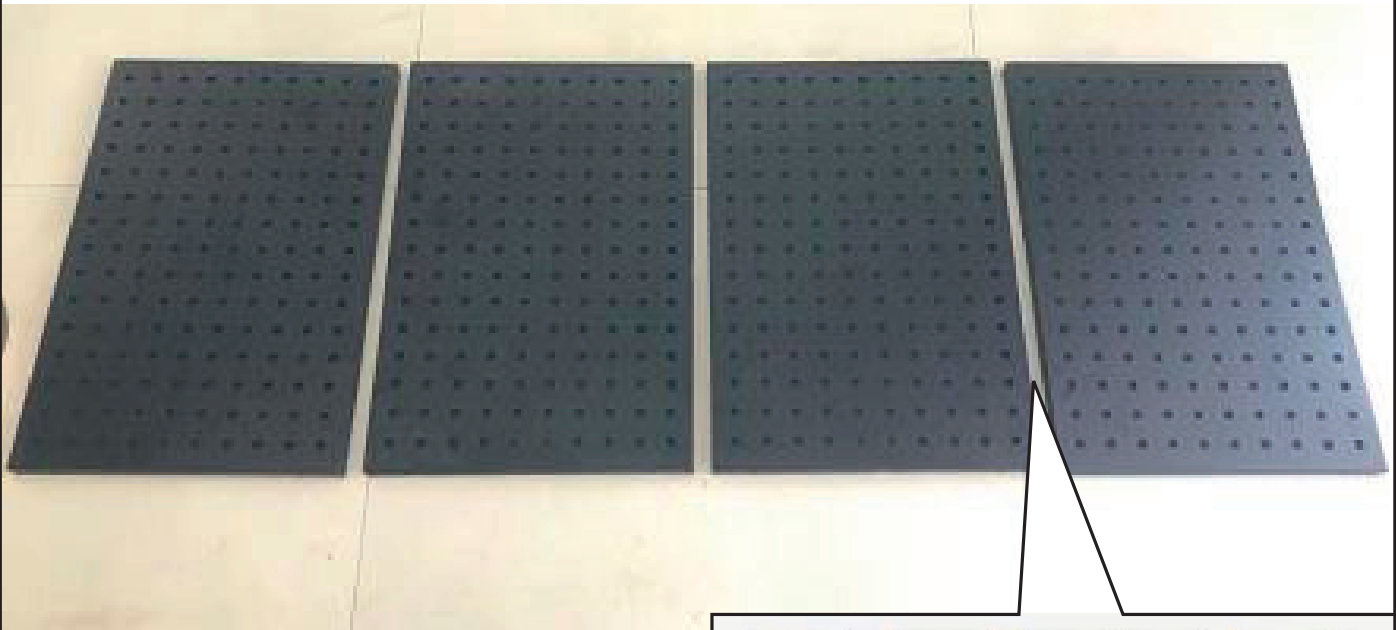

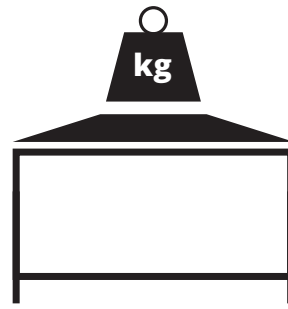

max. 200 kg





40495.4

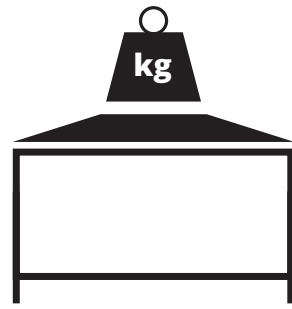

max. 200 kg

3

14x

16 



4

4x

17 



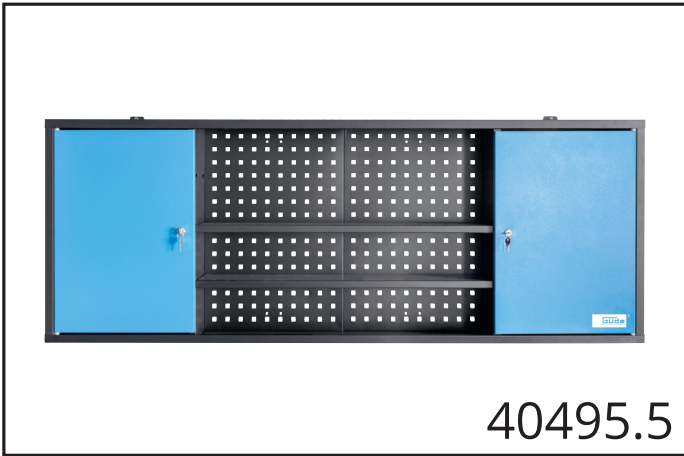

40495.5

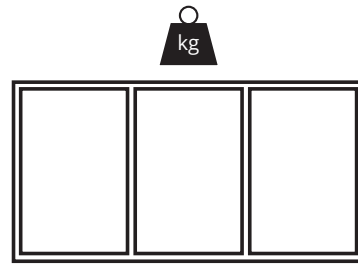

max. 48 kg

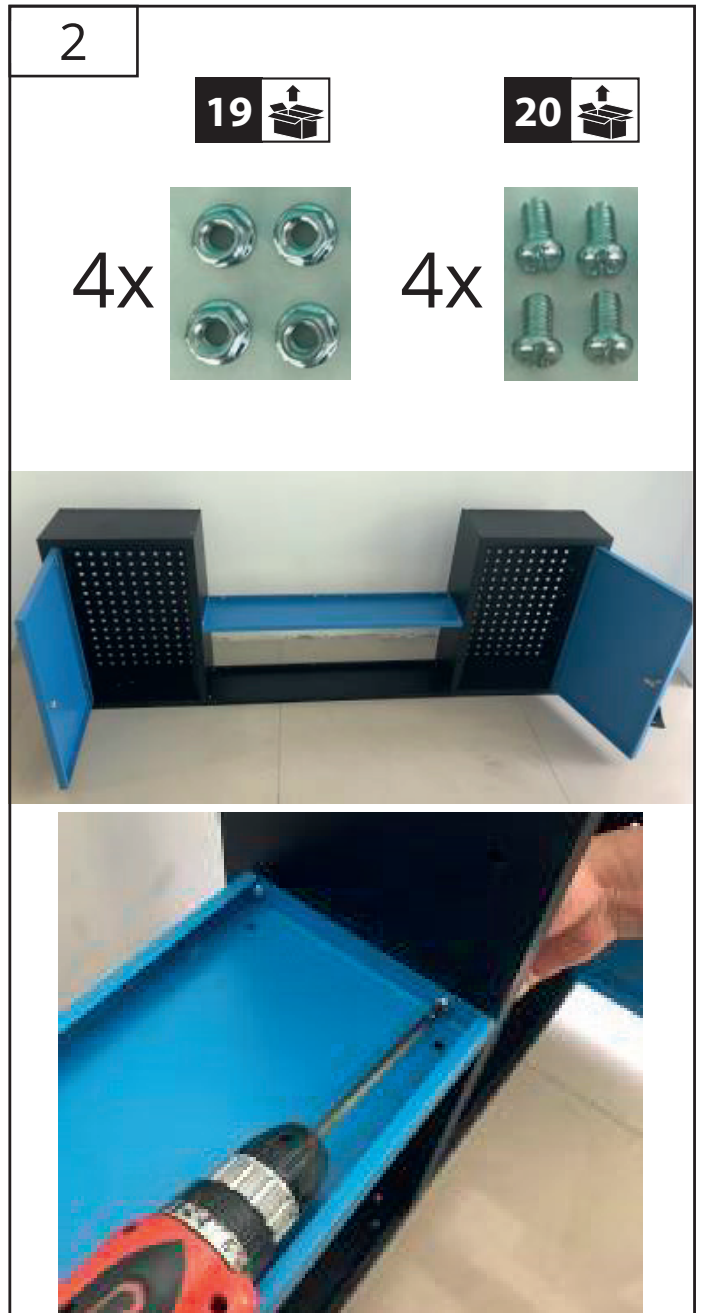

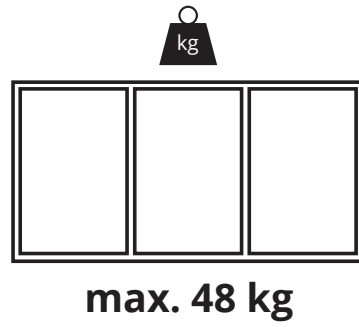
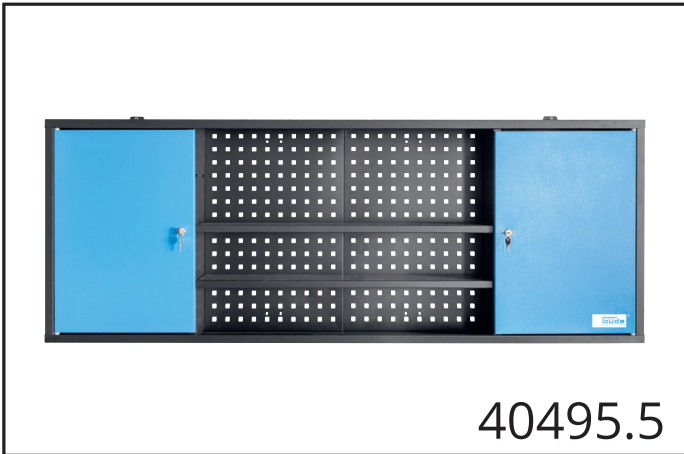



3



19  20 



4x  4x 





4

19  20 

4x  4x 

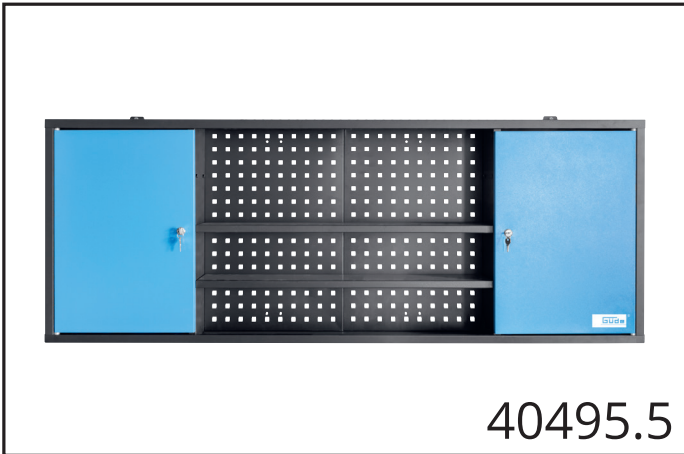

40495.5



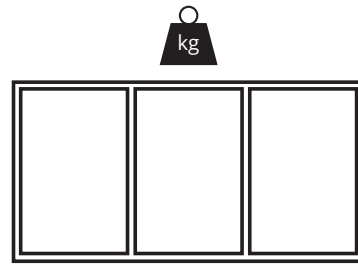

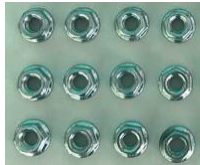

max. 48 kg

5

12x **19** 





12x **20** 







6

19 

4x 

20 

4x 



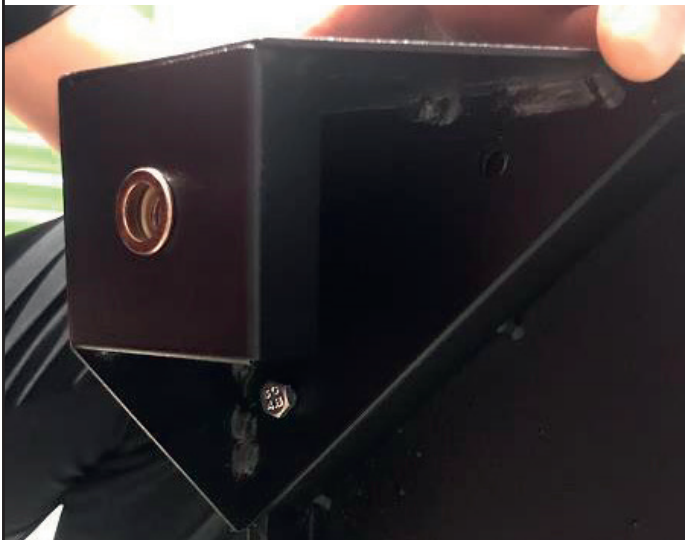
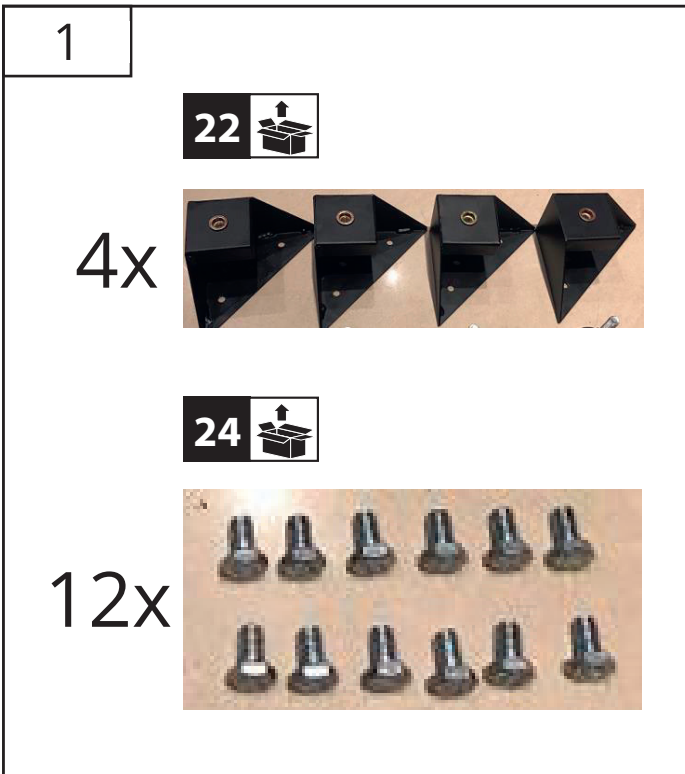
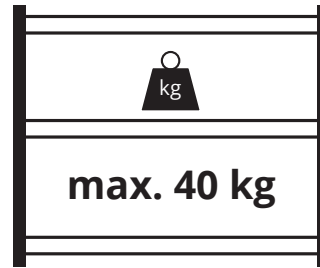

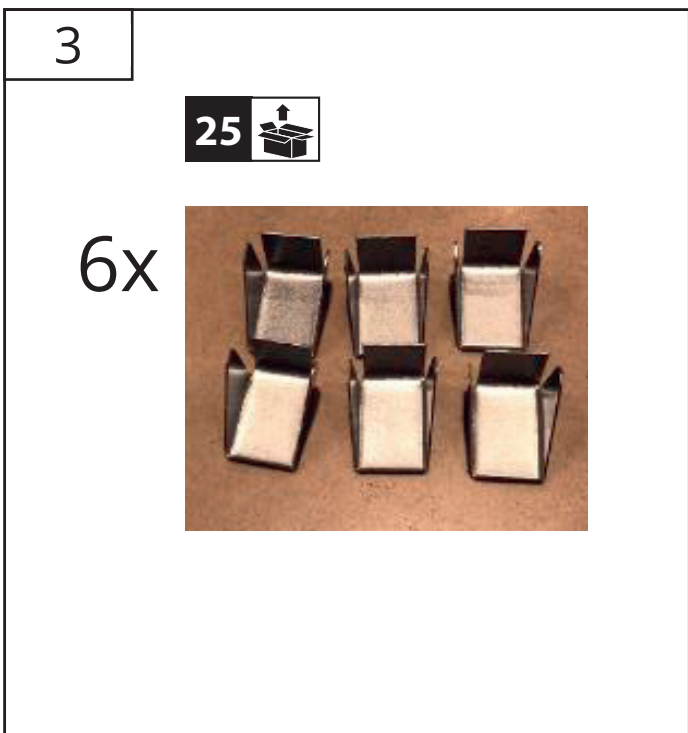
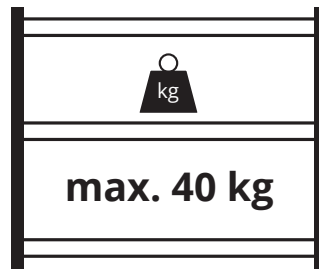







GÜDE GmbH & Co. KG

Birkichstrasse 6

74549 Wolpertshausen

Deutschland

Tel.: +49-(0)7904/700-0

Fax.: +49-(0)7904/700-250

eMail: info@guede.com

www.guede.com